

# CONEN MOUNTS

Fixed height systems for (interactive) displays up to 100"

## Fixed height systems with mobile stand



### SCETANHW..

Fixed height, central aluminum column with VESA display mount. Mobile stand with V-shaped stand with 4 heavy duty castors, 2 lockable.

#### Features:

- Frame for all 42" – 100" Displays
- VESA horizontal: 200 – 800  
VESA vertical: 200 – 600
- Fits heavy displays
- Maximum weight load 150 kg
- V-shaped mobile stand, RAL 7021 black grey

Image shows:  
SCETANHW14



ACCESSORIES

90

from page

Image shows: SCETANHW12  
with Clevertouch Plus display

### Accessories – Informations see page 90



#### Front shelf

- Dimensions, W/D: 62 x 44 cm

Item no. FSH-..



#### 1 side shelf

- Dimensions, W/D: 45 x 32,5 cm
- Mounting at left or right side

Item no. LAP4-..

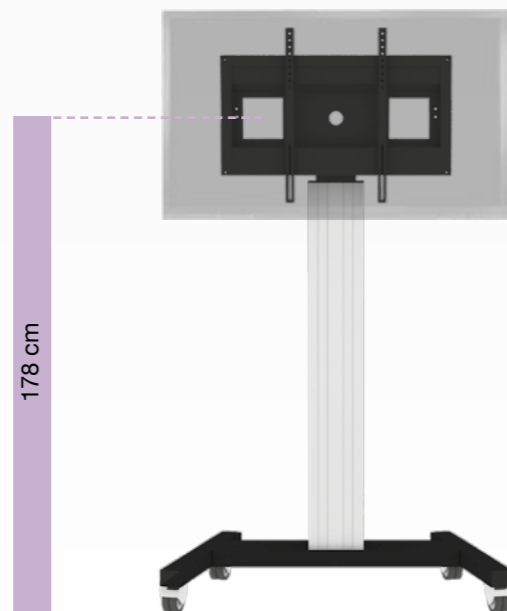

- Height: 178 cm
- Signage height

Column natural anodized

Item no. SCETANHW14

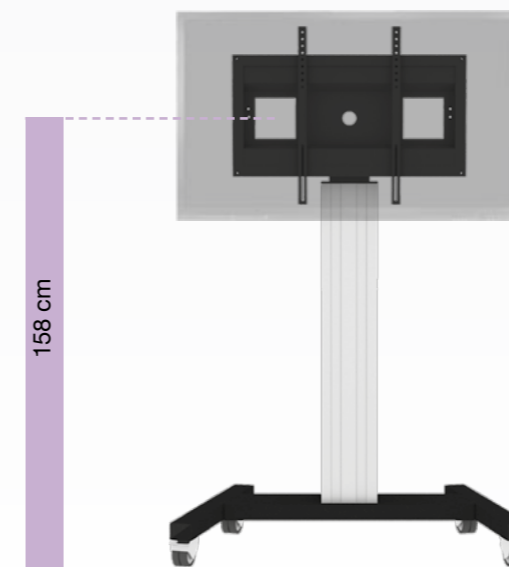

- Height: 158 cm
- Working height adult

Column natural anodized

Item no. SCETANHW12

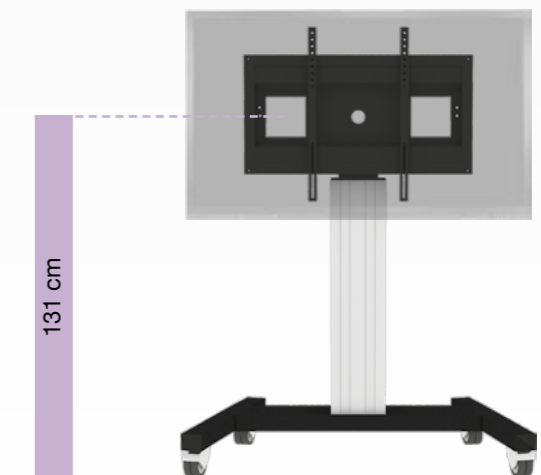

- Height: 131 cm
- Working height primary and secondary school

Column natural anodized

Item no. SCETANHWV