

CONEN MOUNTS

Height adjustable systems for (interactive) displays from 70"

Electrically height adjustable system with 2 columns with mobile stand
 – VESA 800/ 1000/ 1200

SCETAD..

Height adjustable double aluminum columns with XL-VESA frame for displays. Mobile cart with H-shaped stand with 4 heavy duty castors, 2 lockable.

Features:

- Frame for all 70" – 120" Displays
- VESA horizontal: 800/ 1000/ 1200
VESA vertical: 200 – 600
- Fits very heavy displays
- Maximum weight load 250 kg
- H-shaped mobile stand, RAL 9006 white aluminum

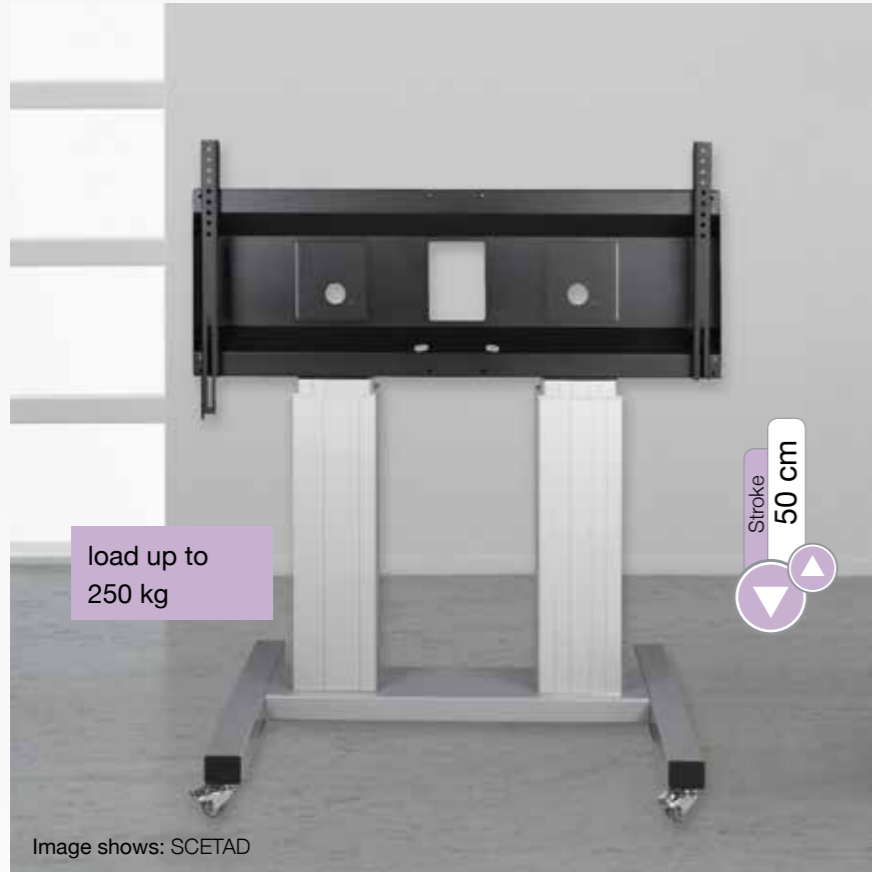
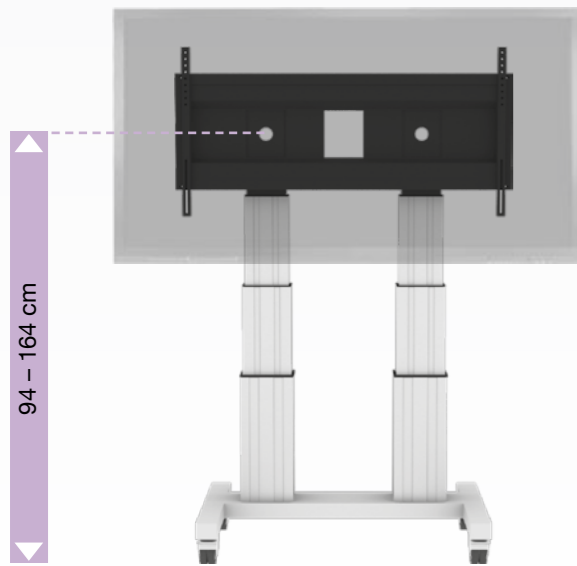

Image shows: SCETAD



Image shows: SCETAD3535B with Clevertouch Plus display



- 2 x 35 cm stroke
- Early years – adult

Column natural anodized

Item no. SCETAD3535

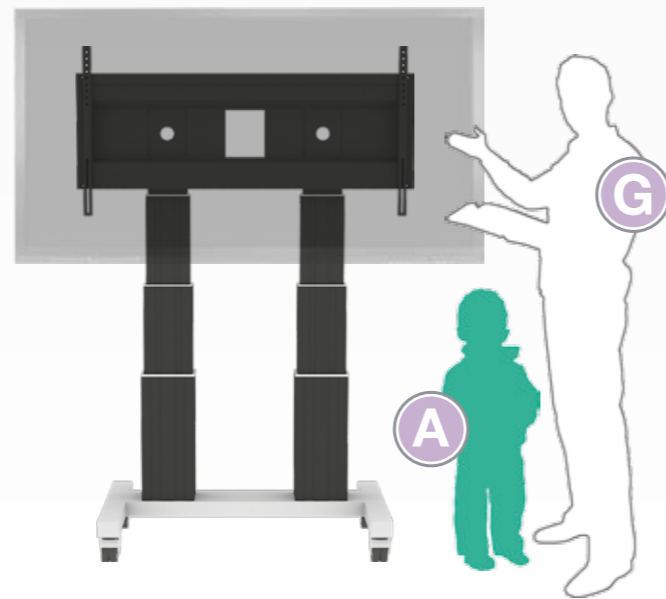

Column black anodized

Item no. SCETAD3535B

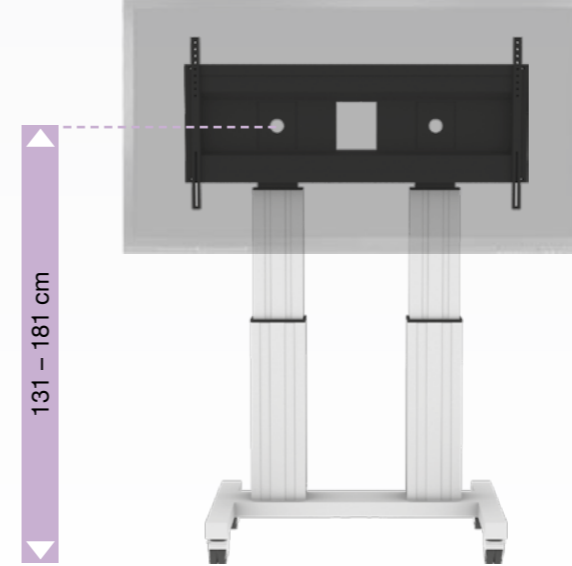

- 50 cm stroke
- Secondary school – adult

Column natural anodized

Item no. SCETAD

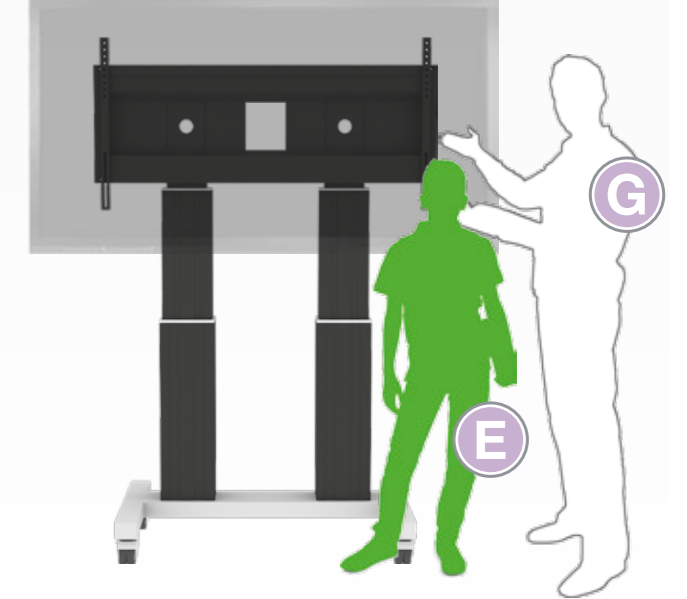

Column black anodized

Item no. SCETADB